

EN

OPERATING MANUAL
DYNAMIC PRESSURE
ANEMOMETER



Table of contents

Notes regarding the operating manual..... 2

Safety 2

Information about the device..... 3

Transport and storage..... 6

Operation 6

Software..... 10

Errors and faults 11

Maintenance and repair 11

Disposal 11

Notes regarding the operating manual

Symbols

 **Warning of electrical voltage**
This symbol indicates dangers to the life and health of persons due to electrical voltage.

 **Warning**
This signal word indicates a hazard with an average risk level which, if not avoided, can result in serious injury or death.

 **Caution**
This signal word indicates a hazard with a low risk level which, if not avoided, can result in minor or moderate injury.

Note
This signal word indicates important information (e.g. material damage), but does not indicate hazards.

 **Info**
Information marked with this symbol helps you to carry out your tasks quickly and safely.

 **Follow the manual**
Information marked with this symbol indicates that the operating manual must be observed.

You can download the current version of the operating manual and the EU declaration of conformity via the following link:



TA400



<https://hub.trotec.com/?id=43622>

Safety

Read this manual carefully before starting or using the device. Always store the manual in the immediate vicinity of the device or its site of use.

-  **Warning**
Read all safety warnings and all instructions. Failure to follow the warnings and instructions may result in electric shock, fire and/or serious injury.
Save all warnings and instructions for future reference.
- Do not use the device in potentially explosive rooms or areas and do not install it there.
 - Do not use the device in aggressive atmosphere.
 - Do not immerse the device in water. Do not allow liquids to penetrate into the device.
 - The device may only be used in dry surroundings and must not be used in the rain or at a relative humidity exceeding the operating conditions.
 - Protect the device from permanent direct sunlight.
 - Do not expose the device to strong vibrations.
 - Do not remove any safety signs, stickers or labels from the device. Keep all safety signs, stickers and labels in legible condition.
 - Do not open the device.
 - Never charge batteries that cannot be recharged.
 - Different types of batteries and new and used batteries must not be used together.
 - Insert the batteries into the battery compartment according to the correct polarity.
 - Remove discharged batteries from the device. Batteries contain materials hazardous to the environment. Dispose of the batteries according to the national regulations.
 - Remove the batteries from the device if you will not be using the device for a longer period of time.
 - Never short-circuit the supply terminal in the battery compartment!

- Do not swallow batteries! If a battery is swallowed, it can cause severe internal burns within 2 hours! These burns can lead to death!
- If you think batteries might have been swallowed or otherwise entered the body, seek medical attention immediately!
- Keep new and used batteries and an open battery compartment away from children.
- Observe the storage and operating conditions (see Technical data).

Intended use

Only use the device for indoor measurements of air pressure, velocity, volume flow and temperature within the measuring range specified in the technical data. Observe and comply with the technical data.

To use the device for its intended use, only use accessories and spare parts which have been approved by Trotec.

Foreseeable misuse

Do not use the device in potentially explosive atmospheres, for measurements in liquids or at live parts.

Any unauthorised changes, modifications or alterations to the device are forbidden.

Personnel qualifications

People who use this device must:

- have read and understood the operating manual, especially the Safety chapter.

Residual risks



Warning of electrical voltage

There is a risk of a short-circuit due to liquids penetrating the housing!
Do not immerse the device and the accessories in water. Make sure that no water or other liquids can enter the housing.



Warning of electrical voltage

Work on the electrical components must only be carried out by an authorised specialist company!



Warning

Risk of suffocation!
Do not leave the packaging lying around. Children may use it as a dangerous toy.



Warning

The device is not a toy and does not belong in the hands of children.



Warning

Dangers can occur at the device when it is used by untrained people in an unprofessional or improper way! Observe the personnel qualifications!



Caution

Keep a sufficient distance from heat sources.

Note

To prevent damages to the device, do not expose it to extreme temperatures, extreme humidity or moisture.

Note

Do not use abrasive cleaners or solvents to clean the device.

Information about the device

Device description

The device can measure the following parameters:

- Air pressure
 - psi
 - mbar
 - inH₂O
 - mmH₂O
 - Pa
- Air velocity
 - metres per second (m/s)
 - feet per minute (ft/min)
 - kilometres per hour (km/h)
 - miles per hour (mph)
 - nautical miles per hour in knots (kn)
- Air volume flow
 - CFM (cubic feet per minute)
 - CMM (cubic metres per minute)
- Air temperature
 - degrees Celsius
 - degrees Fahrenheit

The device is equipped with a HOLD function as well as with a Max/Min value display.

Optionally, it is also possible to read and save measurement data directly on a PC by means of the software included in the scope of delivery.

Device depiction

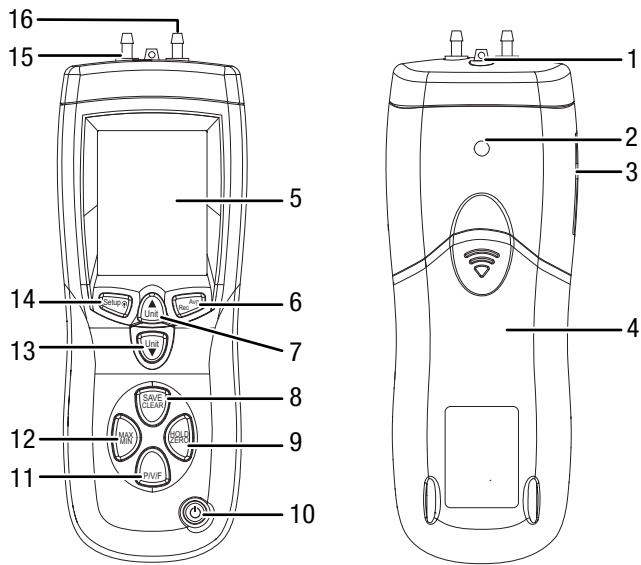

No.	Designation
1	Temperature sensor
2	Tripod thread
3	USB port
4	Battery compartment cover
5	Display
6	AVG/REC button
7	Unit ▲ button
8	SAVE/CLEAR button
9	HOLD/ZERO button
10	Power button
11	P/V/F button
12	MAX/MIN button
13	Unit ▼ button
14	Setup/illumination button
15	- input
16	+ input

Display

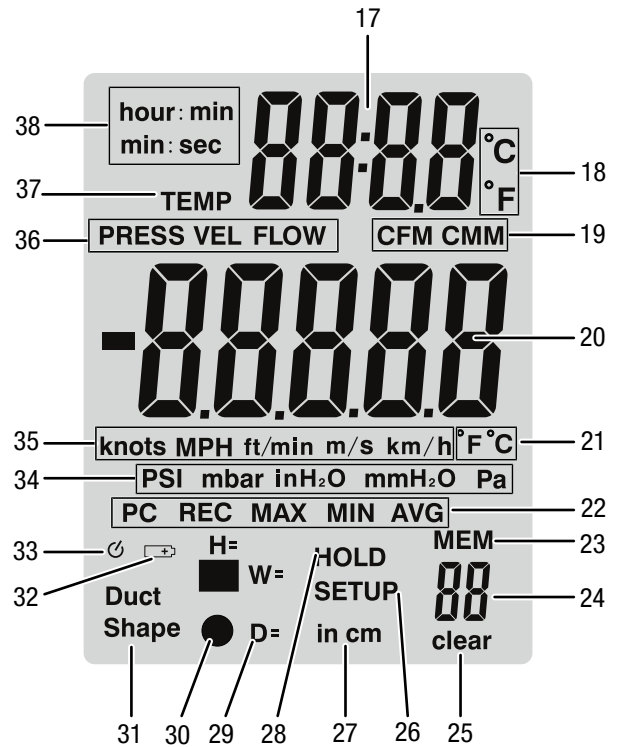

No.	Designation
17	Temperature/time display
18	°C/°F indication for display 17
19	Indication of the units CFM/CMM
20	Measurement value indication
21	°C/°F indication for display 20
22	REC, MAX, MIN, AVG indication
23	MEM indication (memory)
24	Memory space indication
25	Clear memory indication
26	Setup active indication
27	Length unit indication
28	HOLD function active indication
29	Height (H) / width (W) / diameter (D) indication
30	Air duct shape indication (round / angular)
31	Air duct cross-section selection mode active indication
32	Battery status indication
33	Automatic switch-off active indication
34	Indication of the pressure unit
35	Indication of the velocity unit
36	Measuring mode indication
37	TEMP indication
38	Time format indication

Technical data

Parameter	Value
Model	TA400
Dimensions of the device (height x width x depth)	210 x 75 x 50 mm
Weight of the device incl. Pitot tube and battery	540 g
Length of the Pitot tube	335 mm
Diameter of the Pitot tube	8 mm
Hose lengths	850 mm each
Operating conditions	0 °C to +50 °C, < 90 % RH
Storage conditions	0 °C to +50 °C, < 90 % RH
Power supply	1 x 9 V battery
Air pressure	
Accuracy	± 0.3 % at +25 °C
Pressure range	0 to 5000 Pa
Pressure, max.	5000 Pa
Measuring range	PSI: 0.7252 mbar: 50.00 inH ₂ O: 20.07 mmH ₂ O: 509.8 Pa: 5000
Resolution	PSI: 0.0001 mbar: 0.01 inH ₂ O: 0.01 mmH ₂ O: 0.1 Pa: 1
Air velocity	
Measuring range	m/s: 1 to 80.00 ft/min: 200 to 15733 km/h: 3.6 to 288.0 MPH: 2.24 to 178.66 knots: 2.0 to 154.6
Resolution	m/s: 0.01 ft/min: 1 km/h: 0.1 MPH: 0.01 knots: 0.1
Accuracy	m/s: ±2.5 % at 10 m/s ft/min, km/h, MPH, knots: The accuracy depends on the air velocity and the size of the air duct.

Parameter	Value
Air volume flow	
Measuring range	CFM: 0 ft ³ /min to 99,999 ft ³ /min CMM: 0 m ³ /min to 99,999 m ³ /min
Resolution	CFM: 0.0001 to 100 CMM: 0.001 to 100
Temperature	
Measuring range	°C: 0 °C to 50 °C °F: 32.0 °F to 122.0 °F
Resolution	°C: 0.1 °F: 0.1
Accuracy	°C: ± 1.0 °C °F: ± 2.0 °F

Scope of delivery

- 1 x Device TA400
- 1 x 9 V battery
- 1 x Pitot tube
- 1 x Tube, white
- 1 x Tube, black
- 1 x Transport case
- 1 x Mini USB cable
- 1 x CD-ROM with software
- 1 x Quick guide

Transport and storage

Note

If you store or transport the device improperly, the device may be damaged.

Note the information regarding transport and storage of the device.

Transport

For transporting the device, use the transport case included in the scope of delivery in order to protect the device from external influences.

Before transporting the device, please observe the following:

- Remove the hoses from the connections at device and Pitot tube.

Storage

When the device is not being used, observe the following storage conditions:

- dry and protected from frost and heat
- protected from dust and direct sunlight
- For storing the device, use the transport case included in the scope of delivery in order to protect the device from external influences.
- the storage temperature complies with the values specified in the Technical data
- Remove the battery from the device.

Operation

Inserting the battery

Note

Make sure that the surface of the device is dry and the device is switched off.

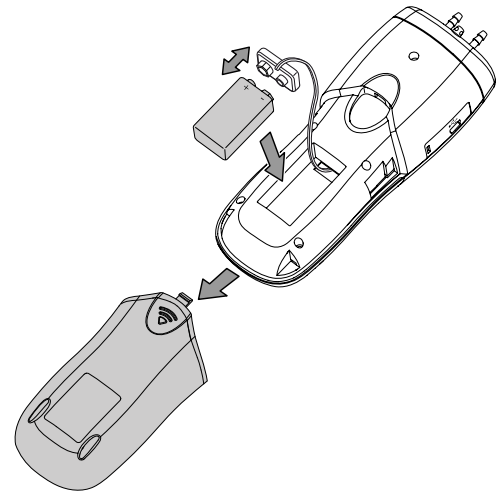

1. Open the battery compartment at the rear of the device by sliding the battery compartment cover (4) down at the arrow mark.
2. Use the battery clip to connect the 9 V battery with correct polarity.
3. Place the battery with the battery clip into the battery compartment.
4. Slide the battery compartment cover (4) back on the battery compartment.
⇒ The cover should click into place.

Switching the device on



Info

Please note that moving from a cold area to a warm area can lead to condensation forming on the device's circuit board. This physical and unavoidable effect can falsify the measurement. In this case, the display shows either no measured values or they are incorrect. Wait a few minutes until the device has become adjusted to the changed conditions before carrying out a measurement.

1. Press the Power button (10).
⇒ The device is switched on.

Measuring the differential pressure

In the measuring mode for *differential pressure measurements* the differential pressure of a zone 1 can be determined with regard to a reference environment (zone 2 / equipment location).

The differential pressure can be indicated in 5 different units:

- PSI
- mbar
- inH₂O
- mmH₂O
- Pa

1. Connect the white tube to the + input (16).
⇒ The - input (15) will not be connected to a tube.

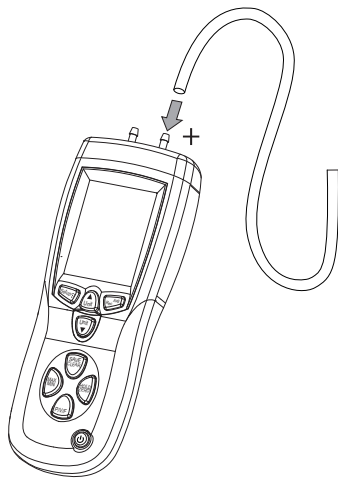

2. Press the *P/V/F* button (11) until *PRESS* appears in the measuring mode display (36).
3. Press the *Unit* ▼ button (13) to select the desired unit for the measurement.
⇒ The selected unit appears in the pressure unit display (34).
4. Press the *HOLD/ZERO* button (9) for approx. 2 s to reset the saved measured values to zero.
5. Position the free end of the tube in the area (zone 1) the differential pressure of which is to be determined with regard to the measuring device (zone 2).
⇒ The measured differential pressure value will be indicated in the measurement value indication (20).
⇒ A positive measured value indicates that the pressure in zone 1 is higher than in zone 2.
⇒ A negative measured value indicates that the pressure in zone 1 is lower than in zone 2.
⇒ The measured value 0 indicates an identical pressure in both zones.

Note:

Additionally, you can connect the black tube to the - input (15). Bear in mind that in that case the reference environment zone 2 is equivalent to the end of the black tube, not the device location.

Measuring the air velocity

In the measuring mode for *air velocity measurements* the current air velocity is measured with defined standard conditions (temperature 21.1 °C / 70 °F, air pressure 14.7 psi / 1013 mbar).

The air velocity can be indicated in 5 different units:

- metres per second (m/s)
- feet per minute (ft/min)
- kilometres per hour (km/h)
- miles per hour (mph)
- nautical miles per hour in knots (kn)

1. Connect the white tube to the + input (16) of both the device and the Pitot tube.
2. Connect the black tube to the - input (15) of both the device and the Pitot tube.



3. Press the *HOLD/ZERO* button (9) for approx. 2 s to reset the measured values to zero.
4. Press the *P/V/F* button (11) until *VEL* appears in the measuring mode display (36).
5. Press the *Unit* ▼ button (13) to select the desired unit for the measurement.
⇒ The selected unit appears in the velocity unit display (35).
6. Point the upper end of the Pitot tube towards the air flow. In doing so, make sure that the Pitot tube is not inclined more than 10° with regard to the air current.
⇒ The measured value will be indicated in the measurement value indication (20).

If a negative measured value or the message *Error* is displayed, please check the connections at Pitot tube and device for proper fit and correct polarity.

Measuring the air volume flow

In the measuring mode for *air volume flow measurements* the air volume flow is measured with defined standard conditions (temperature 21.1 °C / 70 °F, air pressure 14.7 psi / 1013 mbar).

To achieve a measurement that is as accurate as possible, you can indicate round and angular current cross-sections incl. the precise cross-sectional areas.

The air volume flow can be indicated in 2 different units:

- CFM (cubic feet per minute)
- CMM (cubic metres per minute)

1. Connect the white tube to the + input (16) of both the device and the Pitot tube.
2. Connect the black tube to the - input (15) of both the device and the Pitot tube.

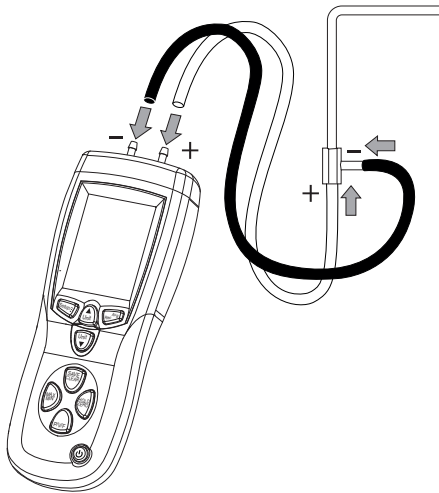

3. Press the *P/V/F* button (11) until *FLOW* appears in the measuring mode display (36).
4. Press the *Unit* ▼ button (13) to select the desired unit for the measurement.
 - ⇒ The selected unit appears in the *CFM/CMM* units display (19).
5. Point the upper end of the Pitot tube towards the air flow. In doing so, make sure that the Pitot tube is not inclined more than 10° with regard to the air current.
 - ⇒ The measured value will be indicated in the measurement value indication (20).

Adjust air duct shape and dimensions

If you want to change details regarding the shape and dimensions of the air duct, please proceed as follows:

1. Press the *Setup/illumination* button (14) for approx. 2 s.
 - ⇒ The setup menu will be opened.
2. Repeatedly press the *Unit* ▲ (7) or *Unit* ▼ button (13) until the indication *Duct Shape* (31) appears.
3. Press the *AVG/REC* button (6) to confirm the selection.
 - ⇒ The submenu for the air duct shape will be opened.
4. Press the *Unit* ▲ (7) or *Unit* ▼ button (13) to choose the quadrangular or round air duct shape.
5. Press the *AVG/REC* button (6) to confirm the selection.
 - ⇒ The air duct shape is selected.

If you selected a **round air duct**, you can now specify the diameter (*D=*) in cm:

- ✓ *D=* is displayed on the indication (29).
1. Press the *Unit* ▲ (7) or *Unit* ▲ (13) button to change the position of the decimal point.
 2. Press the *SAVE/CLEAR* button (8) to select a digit.
 - ⇒ The currently selected digit flashes.
 3. Press the *Unit* ▲ (7) or *Unit* ▼ button (13) to adjust the value (ranging between 0 and 9).
 4. Repeat these steps until the air duct diameter is indicated correctly.
 5. Press the *AVG/REC* button (6) to save the setting.
 - ⇒ The menu item *Type* is displayed.
 6. Press the *Setup* button (14) for approx. 2 s to exit the settings menu.

If you selected a **quadrangular air duct**, you can now specify its width (*W=*) and height (*H=*) in cm:

- ✓ *W=* is displayed on the indication (29).
1. Press the *Unit* ▲ (7) or *Unit* ▲ (13) button to change the position of the decimal point.
 2. Press the *SAVE/CLEAR* button (8) to select a digit.
 - ⇒ The currently selected digit flashes.
 3. Press the *Unit* ▲ (7) or *Unit* ▼ button (13) to adjust the value (ranging between 0 and 9).
 4. Repeat these steps until the width of the air duct is indicated correctly.
 5. Press the *AVG/REC* button (6) to save the setting.
 - ⇒ *H=* is displayed on the indication (29).
 6. Repeat the steps for setting the width until the height of the air duct is also indicated correctly.
 7. Press the *AVG/REC* button (6) to save the setting.
 - ⇒ The menu item *Type* is displayed.
 8. Press the *Setup* button (14) for approx. 2 s to exit the settings menu.

Measuring the air temperature

The air temperature will be indicated in the temperature/time display (17).

In the measuring mode you can always switch between the units °C and °F:

1. Press the *Unit* ▲ button (7).
 - ⇒ The displayed unit will change from °C to °F or vice versa.
 - ⇒ An acoustic confirmation signal will be emitted.

Displaying MIN / MAX / AVG values

The minimum (*MIN*), maximum (*MAX*) and average (*AVG*) values can be determined via a measurement interval.

1. Press the *MAX/MIN* button (12) until the desired function is indicated on the display (22).
 - ⇒ The temperature/time display (17) will be switched from temperature to time (min:sec).
 - ⇒ A new measurement interval will be started.
 - ⇒ *REC* is displayed on the indication (22).
2. Press the *MAX/MIN* button (12) to switch between the functions.
3. Press the *MAX/MIN* button (12) for approx. 2 s to return to the normal measuring mode.

Hold function

The currently measured value can be frozen in all measuring modes.

1. Press the *HOLD/ZERO* button (9) to freeze the currently measured value.
2. Press the *HOLD/ZERO* button (9) again to deactivate the hold function.

Saving and calling up measured values

In each measuring mode you can save up to 99 data sets.

To save a measured value, please proceed as follows:

1. Press the *SAVE/CLEAR* button (8).
 - ⇒ The current measured value will be saved.
 - ⇒ An acoustic confirmation signal will be emitted.
 - ⇒ The number of saved values below the *MEM* indication (23) is increased by one.

To call up a measured value, please proceed as follows:

1. Press the *AVG/REC* button (6) for approx. 2 s.
 - ⇒ *REC* will be displayed in the temperature/time indication (17).
2. Press the *Unit* ▲ (7) or *Unit* ▲ (13) button to choose the desired memory location.
 - ⇒ The saved measured value is displayed in the measurement value indication (20).
3. Press the *AVG/REC* button (6) for approx. 2 s to return to the measuring mode.

Settings

In the setting menu you can adjust some of the basic settings for the device. The following table shows an overview of the available options.

Menu text	Designation	Setting options
<i>Unit</i>	Unit for the air duct dimensions	for determining the unit in which the air duct dimensions will be indicated
<i>Duct Shape</i>	Settings for the air duct	for specifying the shape and dimensions of the air duct
<i>Type</i>	Display options for measuring modes	1 = measuring modes for air pressure and air velocity 2 = measuring modes for air velocity and air volume flow 3 = measuring modes for air pressure, air velocity and air volume flow
<i>Sleep</i>	Automatic switch-off	for de-/activating the automatic switch-off function
<i>ALL</i>	Clear memory	for clearing the memory; yes or no

To access the setup menu, please proceed as follows:

- ✓ The device is switched on.
- 1. Press the *Setup* button (14) for approx. 2 s.
 - ⇒ The setup menu will be opened.
- 2. Select the desired option using the *Unit* ▲ (7) or *Unit* ▼ button (13).
- 3. Press the *AVG/REC* button (6) to confirm the selection.
 - ⇒ The desired submenu will be opened.

Setting the measuring unit for the air duct

1. Press the *Setup* button (14) for approx. 2 s.
⇒ The setup menu will be opened.
2. Repeatedly press the *Unit* ▲ (7) or *Unit* ▼ button (13) until *unit* is displayed.
3. Press the *AVG/REC* button (6) to confirm the selection.
⇒ The length indication (27) displays the currently selected unit (in or cm).
4. Repeatedly press the *Unit* ▲ (7) or *Unit* ▼ button (13) until the desired unit is displayed.
5. Press the *AVG/REC* button (6) to save the setting.
6. Press the *Setup* button (14) for approx. 2 s to exit the settings menu.

Deleting saved measurements

There are two ways to delete measured values:

- Deleting all saved measurements
- Deleting a certain measured value

To delete **all** saved entries, please proceed as follows:

1. Press the *Setup* button (14) for approx. 2 s.
⇒ The setup menu will be opened.
2. Repeatedly press the *Unit* ▲ (7) or *Unit* ▼ button (13) until *ALL* is displayed.
⇒ At the same time the clear memory indication (25) appears in the bottom right corner.
3. Press the *AVG/REC* button (6) to confirm the selection.
⇒ The measuring modes are indicated in the measuring mode display (36).
⇒ *YES* will be indicated in the temperature/time display (17).
4. Press the *Unit* ▲ (7) or *Unit* ▼ button (13) to choose whether to delete the memory (*yes*) or not (*no*).
5. Press the *AVG/REC* button (6) to confirm the selection.
6. Press the *Setup* button (14) for approx. 2 s to exit the settings menu.

To delete **one** specific measured value, please proceed as follows:

1. Press the *AVG/REC* button (6) for approx. 2 s.
⇒ *REC* will be displayed in the temperature/time indication (17).
2. Press the *Unit* ▲ (7) or *Unit* ▼ button (13) to choose the desired memory location.
⇒ The saved measured value is displayed in the measurement value indication (20).
3. Press the *SAVE/CLEAR* button (8).
⇒ The selected measurement will be deleted.
⇒ An acoustic confirmation signal will be emitted.
⇒ The next saved measurement will be displayed.
4. Press the *AVG/REC* button (6) for approx. 2 s to return to the measuring mode.

Setting the automatic switch-off

If automatic switch-off is activated, the device switches off automatically after approx. 5 minutes of non-use.

1. Press the *Setup* button (14) for approx. 2 s.
⇒ The setup menu will be opened.
2. Repeatedly press the *Unit* ▲ (7) or *Unit* ▼ button (13) until *SLEEP* is displayed.
3. Press the *AVG/REC* button (6) to confirm the selection.
⇒ *On* or *off* (activated or deactivated automatic switch-off) will be indicated in the temperature/time display (17).
4. Press the *Unit* ▲ (7) or *Unit* ▼ button (13) to choose the desired setting.
5. Press the *AVG/REC* button (6) to confirm the selection.
6. Press the *Setup* button (14) for approx. 2 s to exit the settings menu.

Setting the background illumination

The display comes with a background illumination that can be switched on as needed.

1. Press the *Setup* / illumination button (14) to switch the background illumination on or off.

Switching the device off

1. Press the Power button (10).
⇒ The device is switched off.

Software

The supplied free software is designed for useful basic functionalities. Trotec assumes no liability with regard to this free software and also provides no support on that score. Trotec accepts no liability concerning the use of this free software and is under no obligation to make adjustments or to further develop updates or upgrades.

Installation requirements

Ensure that the following minimum requirements for installing the PC software are fulfilled:

- Supported operating systems (32 or 64 bit version):
 - Windows 10
 - Windows 8
 - Windows 7
 - Windows Vista
 - Windows XP
- Hardware requirements:
 - processor speed: min. 90 MHz
 - 32 MB RAM, minimum
 - 7 MB hard disk space, minimum
 - a minimum screen resolution of 1024 x 768 with a 16 bit colour depth

Installing the PC software

Administrator rights are required for the software installation.

1. Place the supplied software CD into the CD-ROM drive.
2. Open the CD-ROM contents in an Explorer window and double-click the *setup.exe* file.
3. Follow the instructions of the installation wizard.

Starting the PC software

1. Connect the measuring device to your PC via the mini USB cable provided in the scope of delivery.
2. Switch on the measuring device if necessary.
3. Start the *Manometer&Flowmeter* software.

Information about using the PC software is provided in the online help.

Errors and faults

The device has been checked for proper functioning several times during production. If malfunctions occur nonetheless, check the device according to the following list.

Indication	Cause	Remedy
OL	air pressure or air velocity above the measuring range	<ul style="list-style-type: none"> • Check the battery voltage and insert a new high quality battery for testing purposes.
-OL	air pressure below the measuring range	<ul style="list-style-type: none"> • Choose a different location for measuring. <p>If the message continues to be displayed, carry out a reference measurement at a known location:</p>
Error	air velocity or air volume flow below the measuring range	<ol style="list-style-type: none"> 1. Choose a site within the measuring range for this measurement. 2. Press the <i>HOLD/ZERO</i> button (9) for approx. 2 s to reset the saved measured values to zero. 3. Read the measured value from the measurement value display (20). <p>If the error code is still displayed, the device may be defective. Please contact the Trotec customer service.</p>

Maintenance and repair

Battery change

A battery change is required when the battery status indication (32) lights up or the device can no longer be switched on (see chapter Inserting the battery).

Cleaning

Clean the device with a soft, damp and lint-free cloth. Make sure that no moisture enters the housing. Do not use any sprays, solvents, alcohol-based cleaning agents or abrasive cleaners, but only clean water to moisten the cloth.

Repair

Do not modify the device or install any spare parts. For repairs or device testing, contact the manufacturer.

Disposal

Always dispose of packing materials in an environmentally friendly manner and in accordance with the applicable local disposal regulations.



The icon with the crossed-out waste bin on waste electrical or electronic equipment stipulates that this equipment must not be disposed of with the household waste at the end of its life. You will find collection points for free return of waste electrical and electronic equipment in your vicinity. The addresses can be obtained from your municipality or local administration. You can also find out about other return options that apply for many EU countries on the website <https://hub.trotec.com/?id=45090>. Otherwise, please contact an official recycling centre for electronic and electrical equipment authorised for your country.

The separate collection of waste electrical and electronic equipment aims to enable the re-use, recycling and other forms of recovery of waste equipment as well as to prevent negative effects for the environment and human health caused by the disposal of hazardous substances potentially contained in the equipment.



In the European Union, batteries and accumulators must not be treated as domestic waste, but must be disposed of professionally in accordance with Directive 2006/66/EC of the European Parliament and of the Council of 6 September 2006 on batteries and accumulators. Please dispose of batteries and accumulators according to the relevant legal requirements.

Only for United Kingdom

According to Waste Electrical and Electronic Equipment Regulations 2013 (SI 2013/3113) (as amended) and the Waste Batteries and Accumulators Regulations 2009 (SI 2009/890) (as amended), devices that are no longer usable must be collected separately and disposed of in an environmentally friendly manner.

Trotec GmbH

Grebener Str. 7
D-52525 Heinsberg

☎ +49 2452 962-400

☎ +49 2452 962-200

✉ info@trotec.com

www.trotec.com